



I INTELLIGENT BATTERY

Industrial Battery(High capacity industrial Battery)



 **TMSB Co., Ltd.**

Head Office 207B, Incheon Defense Venture Center, 12, Gaetbeol-ro, Yeonsu-gu, Incheon, Korea

Tel. 82-32-260-3350~1 Fax. 82-32-260-3352

Factory 801-1, Juan Sibeom gongdan, 58, Juyeom-ro, Nam-gu, Incheon, Korea

Tel. 82-32-577-5066 Fax. 82-32-579-5066

 **TMSB Co., Ltd.**

Beginning a brighter world!



CEO'S MESSAGE



Company producing next-generation green energy

Thinking ahead with challenge spirit, we'll become an Eco-friendly company

For 17 years, We only have concentrated all the efforts to develop and produce heavy industrial Lithium -Ion Battery power systems uniquely first in Korea. And cultivated new lithium battery markets. Now, we are proud of ourselves to become a major company to supply Lithium Ion Power systems. We, TMSB Co. thinking the environment as well as the technology , will continue to increase our investment and best efforts to become one of the responsible companies to our environment as developing the newest eco friendly technologies for the better lithium series battery packs. The IIB model of High rate ESS can be applied to various types of Power systems such as UPS, High rate new renewable Energy Storage Systems, large capacity DC Power Backup systems, Power plants including Nuclear plants, large scaled hospitals, Oil industries, Banking systems, IDC, Green energy generation systems(windmill and solar energy)etc. As for military sides, it can be used for power supply systems of battleships and submarine. Especially, the recent success in practical use of Lithium FePO₄ to the 2ndry power supply systems of broad heavy industries will lead us to play a key role in the high capacity battery field. Now and forever, with the belief that Business coexistent cooperation carries over the most efficient management, the principle that open and aboveboard company wins your confidence, and company culture that intercommunication and distribution, we promise you to live up to your expectations that we will do our best to be the specialized green energy company leading battery industry.

CEO **Myung Soo, Lee**

COMPANY HISTORY

History

- May 03, 2012 Establishment of a TMSB main office
- Dec 21, 2012 Establishment of a TMSB branch office
- Jan 10, 2013 Establishment of a factory
- Mar 06, 2013 Venture company registration
- Mar 18, 2013 R&D Center registration
- Mar 16, 2013 Obtaining a ISO9001&KS Q ISO3001 certification
- Mar 17, 2015 Obtaining a equipment maintenance qualification.
- Oct 21, 2015 Obtaining a technical development selection

Patent Status

- Dec 06, 2014 The way of forecasting the life cycle of rechargeable secondary batteries

Companies that create an environment energy of tomorrow

TMSB, the Eco-friendly company saving Green Energy!



Application

Why we have to select an IIB technology for ESS facility

BATTERY?

IIB?

1. Should be safe

* 5 safety-steps (safety vent, PTC, shutdown-separator, additive agent for polymer and Protection circuit) keep the battery secured from overcharging, and 360 independent safety devices are separately working as well.

- UL Safety Reg, #1642 Compliance test passed

2. Credible

* Both parallel and sequential circuit designs are applied.

- No replace of entire stock is needed, but only replenish quantity as consumed or additionally required.
- stable power supply even a few cells are partially impaired.

3. Durable in life span

* The Battery has cycle characteristics for long life operations.

- 100% fulfillment of DOD charging cycle criteria, more than 1500 times

4. Economically feasible

* LiFePO4 cells are used for eco friendliness and long life span.
* The high energy density per cell, per volume or per mass enables batteries lighter and smaller.
* The embedded BMS function is stalled.

- High precision-cell balancing function extends cell life span
- BMS including SOC and SOH
- realization of proven high voltage charging technology for high capacity ESS
- LiFePO4 battery system needs no separated storage room

5. User friendly

* No activities for Equalizing charge or refilling electrolyte are required.
* Embedded smart chip provides a remote-monitoring function.
- No maintenance required
- Checking functions of Voltage/current/remaind time/graphical display/alarm, etc
* Networking function for smart grid
* Communication protocols such as TCP/IP, RS232/422/485, CAN, WIFI, etc

6. Eco-friendly

* Sulfuric acid, Cd, Pb and Hg free eco friendly substances are used for pollution control for environment and worker's health



Relative Properties

Comparison of characteristics of 2ndry batteries

Special Quality

The feature and advantages of IIB products

Comparison of characteristics of 2ndry batteries

Item	LiFePO ₄ Battery	Lead Storage Battery	Li-ion Battery
Image			
Watt-Hour/Weight	120	20 ~ 40	190 ~ 210
Energy Density/Volume	356	80 ~ 100	420
Operating Temperature	-25 ~ 55℃	0 ~ 40℃	-20 ~ 50℃
Replacement Cycle (DOD 100%)	1500 cycle	150 cycle	300 cycle
Harmful Material	No	Pb, H ₂ SO ₄	No
Formation	Parallel	Serial	Parallel
Memory Effect	No	No	No
Self Discharge	1 ~ 2% / Month	20 ~ 30% / Month	3 ~ 5% / Month
Equalized Charging	Automatic	Hands On	Automatic
Charging Time (Crruent)	1 ~ 2 Hour (1C rate)	12 ~ 18 Hour (0.1C rate)	1 ~ 2 Hour (1C rate)
Norminal Voltage	3.2V	2V	3.7V
Termination Voltage	2.8V	1.75V	3.0V
BMS	Built in	No	Built in
Price Comparison (Endurance life)	0.5 ~ 0.8	1	1.5 ~ 2.5
Weight	1 / 3	1	1 / 2

The feature of IIB products

High Energy Density

The ultra-high density per unit volume and mass enables a lighter and smaller product.

High Rate Discharge

IIB is suitable for a large power UPS or ESS (Maximum 5C-rate discharge).

No Memory Effect

LiFePO₄ batteries has no memory effect, seen in Ni-Cd, Ni-MH, causes charging capacity to be reduced by repeated charging and discharging to in sufficient levels, therefore.

Environment Friendly

Not included materials against environment regulation such as Cd, Pb and Hg.

High Safety

Our batteries can withstand overcharging by applying a 5 step safety componets.
-Certified by UL Safety Standard UL-1642



The advantages of IIB products

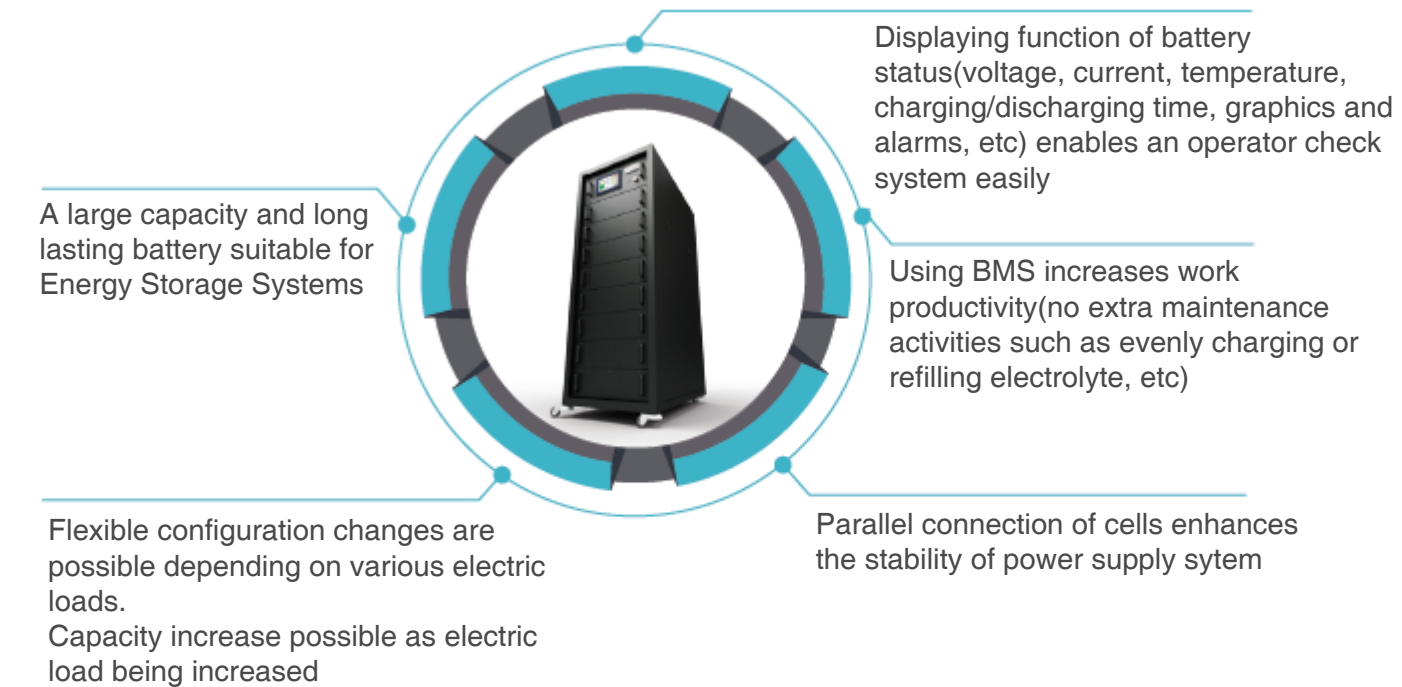



BMS Battery Management System

What is the BMS?

Controlling current while charging/discharging cycle not only protects battery from overcharging or over-discharging but also makes cell balancing when there happens voltage differences among the battery cells. The Battery management system which extends the battery life span uses the algorithm of the state of charge estimation for batteries that can maintain batteries in the most optimal condition.

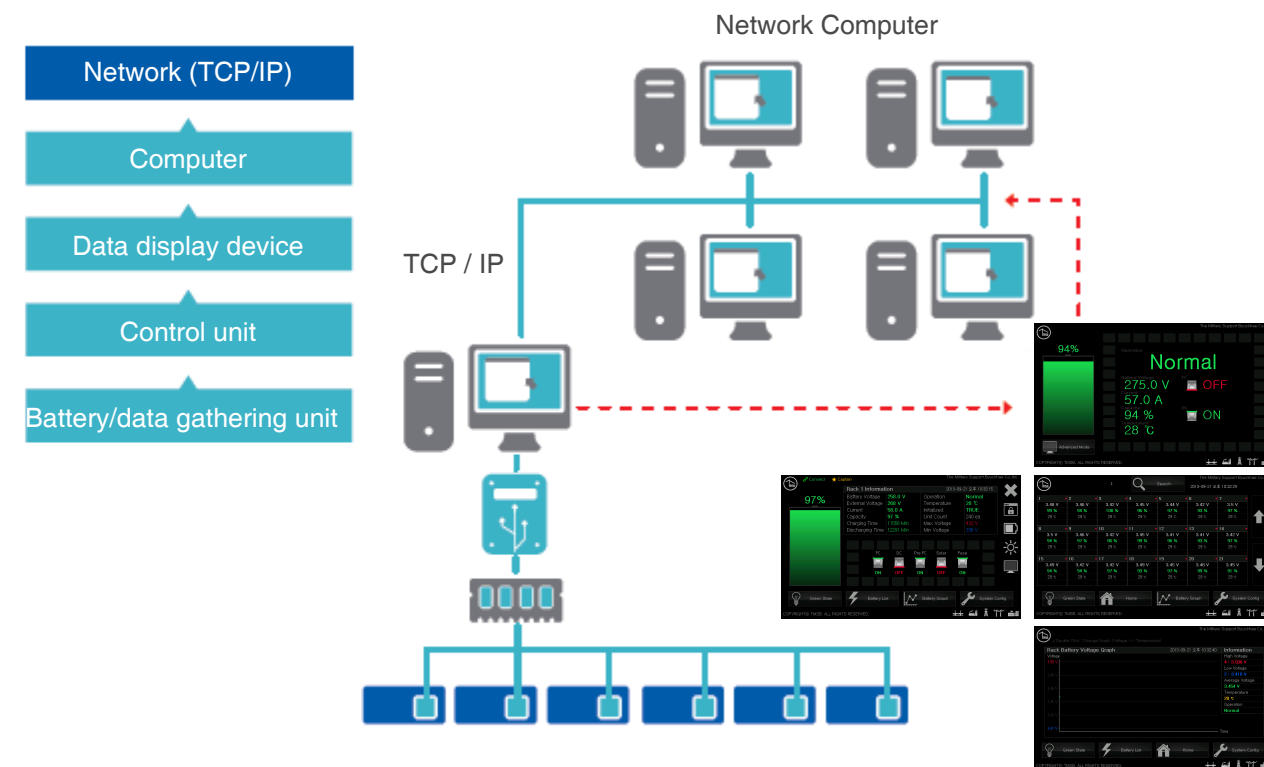

IIB Control Unit

The diagnostic program embedded in IIB provides user the information of PM Estimation, which increases the maintainability of batteries.

A charging unit controller for the new & renewable energy system such as solar electric generator, etc.

- A discharging capacitance control unit enabling batteries efficiently charged with electricity generated from solar energy or wind power generator.
- User programmable and smart grid functionality.
- Compatible with TCP-IP, RS232, RS422, RS485, CAN, and wire/wireless WIFI

Implementing user friendly GUI

- Implementing touch screen and on-screen user manual.
- Display information of unusual condition immediately when occurred.

Protection functionality

- Protection circuit embedded in each cell and the 360 safety steps applied.

BMS BMS effectiveness

BMS effectiveness

What causes battery in trouble

- Abnormal(unusual) temperature
- Inadequate uneven charge of cells
- Loose terminal connection, electrolyte leaking caused by exterior impact, and it's careless management.
- Natural aging

Important factors in battery management

- Impossible to monitor at all time
- To make a manager embarrassed
- Impossible to estimate the disorder of individual cell
- Damage on company's image when accidents occur
- Cost lost on fault recovery from the power failure

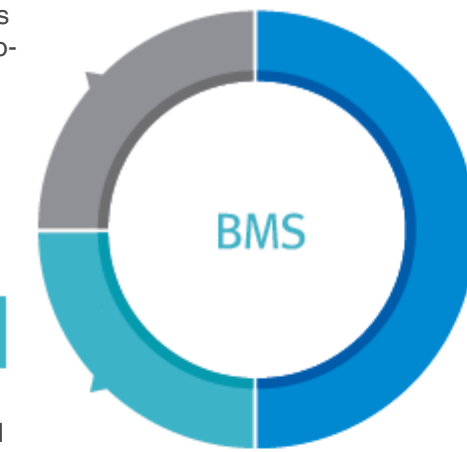

Advantages when BMS applied

- 24-hour battery monitoring
- Voltages, currents and temperatures of battery
- Battery status of Over charging/over discharging and circuit blocking
- Preventive maintenance instruction
- Stable power supply
- Systematic management
- Advance troubles-prediction and counter action
- Anxiety relief for maintenance
- Preventing DB & reducing recovery cost
- Cost saving(cost reduction)
- Trend, Alarm Message
- Customer confidence enhancement

Remote monitoring system





Technology

Possession of IIB technology and functionality

Design & Line-up

Design & Line-up of IIB Products

➤ A device for new & renewable energy, implement the system directly responded from a smart grid.

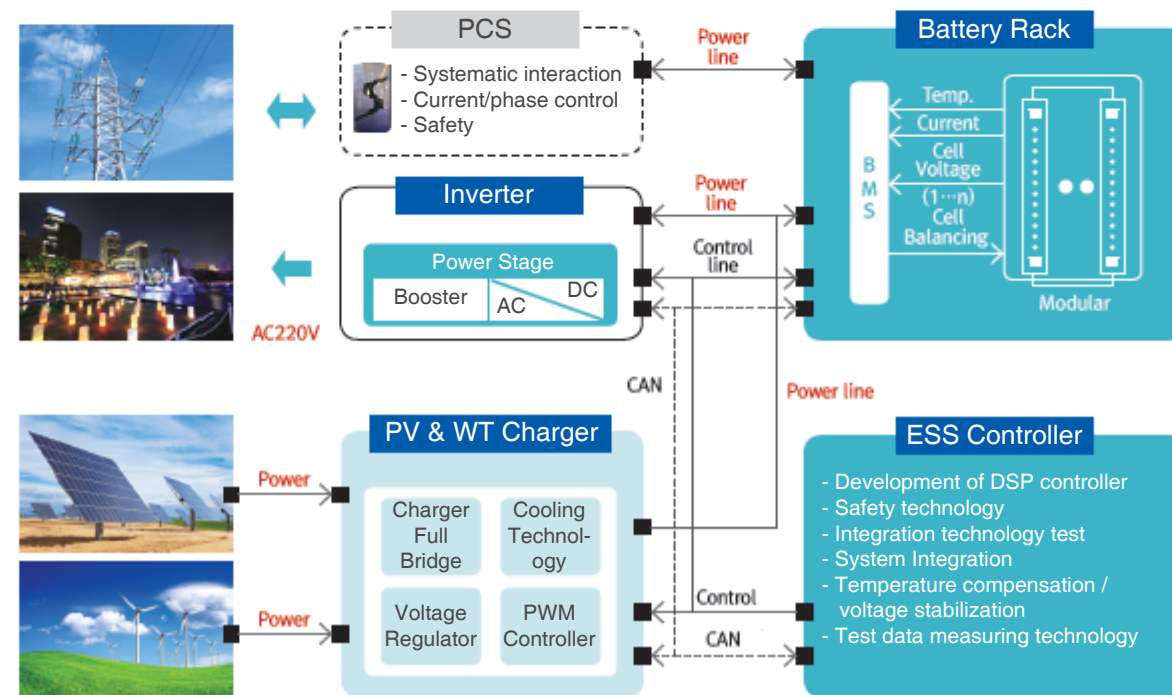

➤ Line-up of IIB Products

Item	Voltage / Capacity	Voltage / Capacity						
		24V/30Ah	124V/30Ah	252V/30Ah	500V/30Ah	912V/30Ah	1102V/30Ah	1314V/30Ah
Input	Rated Voltage	DC 22V	DC 109V	DC 221V	DC 438V	DC 800V	DC 966V	DC 1296V
	Max Voltage	DC 25V	DC 124V	DC 252V	DC 500V	DC 912V	DC 1102V	DC 1314V
Output	Min Voltage	DC 19V	DC 92V	DC 186V	DC 370V	DC 675V	DC 815V	DC 972V
	Cell Type	LiFePO ₄						
Cell Count		14 Cell	68 Cell	138 Cell	274 Cell	500 Cell	604 Cell	720 Cell
Cell Model		40152S						
Cell Capacity		30Ah						

We can supply the optimal system customized and adjusted as customers required. Within the range of voltages from 24v to 1314v, various voltage types of battery packs can be produced/single output voltage per battery pack.



➤ Cell balancing function

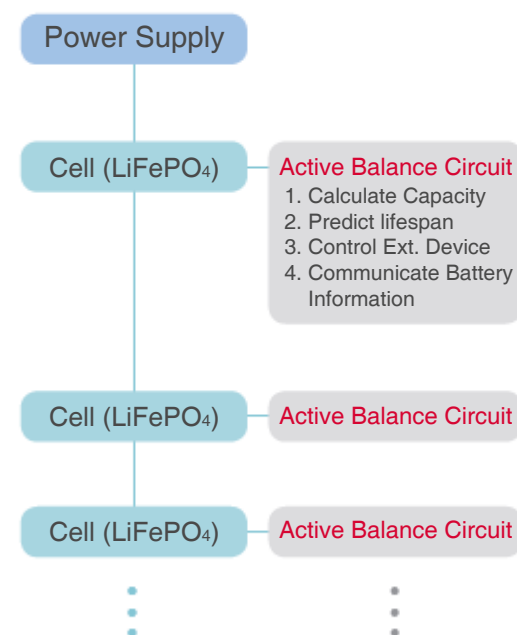

➤ Power increasing/decreasing function New & Renewable energy

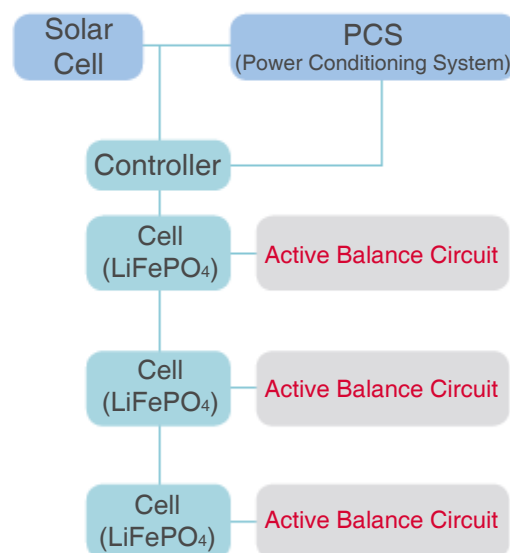

Internet Data Center

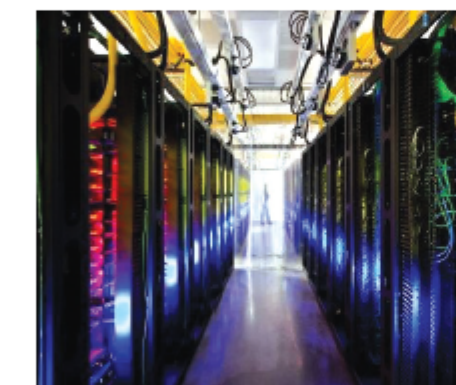

Compatible with existing standard lead-acid battery

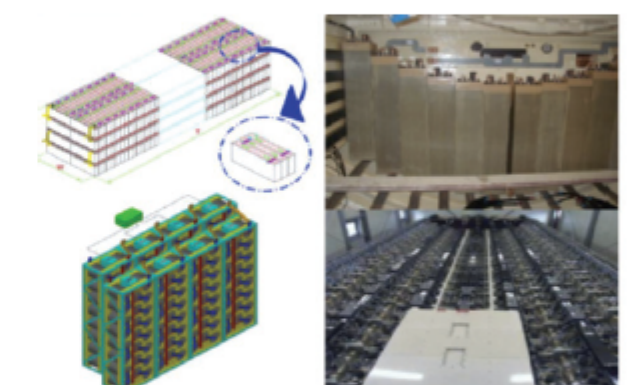

Strength

- Without changing the legacy battery specifications, LiFePO₄ batteries can be accommodated.
- High power density per space
- Wire/Wireless internet access possible for smart grid communications, and compatible to RS485/422/232, CAN, WIFI protocol;

Application Applications of IIB products (ESS)

Apply power system ESS

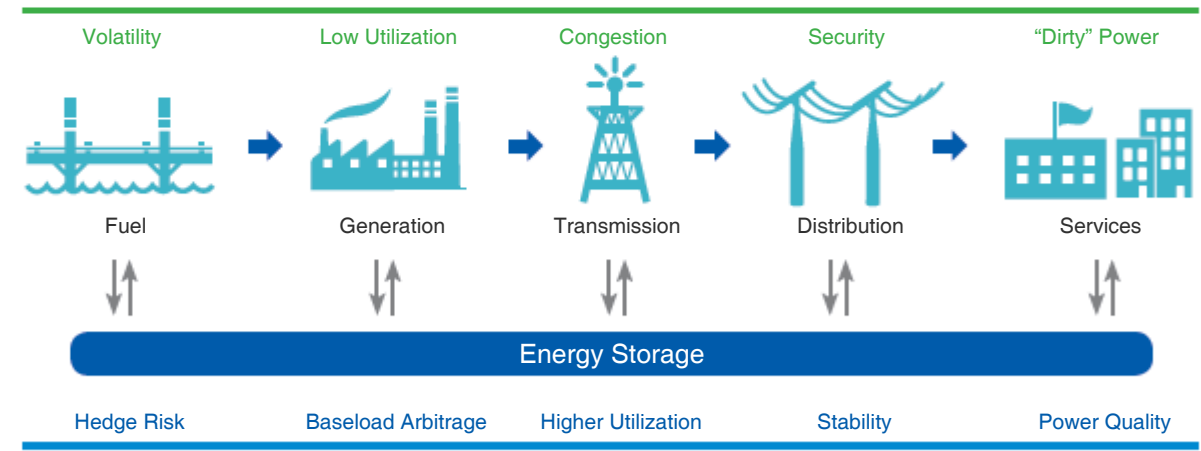

As the typical centralized power generation system, supplying electric power in a batch on customers' demand, could not match the supply to the demand, it tends to waste powers if the peak time of power consumption is not correctly estimated. It's also one of the major culprits to produce pollutants such as co2 by running spare power generators to prepare extra powers for the case of peak consumption.

The ESS having a smart grid and a load leveling functions facilitates the power systems in the most economical running conditions by using the power saved in ESS in the peak time(daytime) while it saves an unused power in the light-load time slot(night time)

Apply market ESS

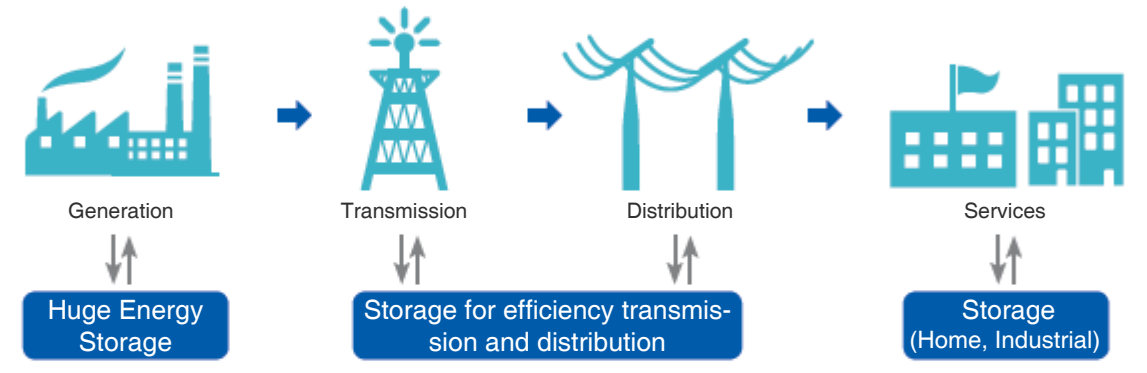

Smart grid ESS is an existing electric power network combined with information technology(IT). It provide a two way, real time information exchange among the suppliers and consumers. By using the ESS, quickly optimize power quality and efficiency using information such as real-time power demand and supply rates. While in the light loading time(night time), spare power is stored, and returned in the daytime, which is called a load leveling

Application Applications of IIB products (ESS)

Load leveling by ESS

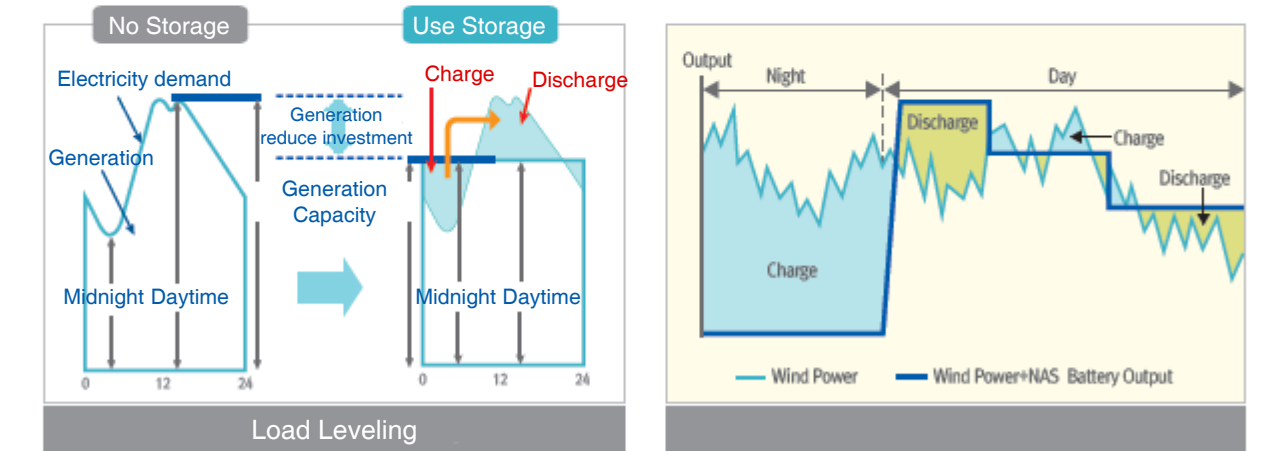

Unstable Outputs of green energy systems, such as Solar or wind power energy systems, can be transformed to highly qualified stable systems by using ESSs.

Reduction of Energy cost can be realized through ESS

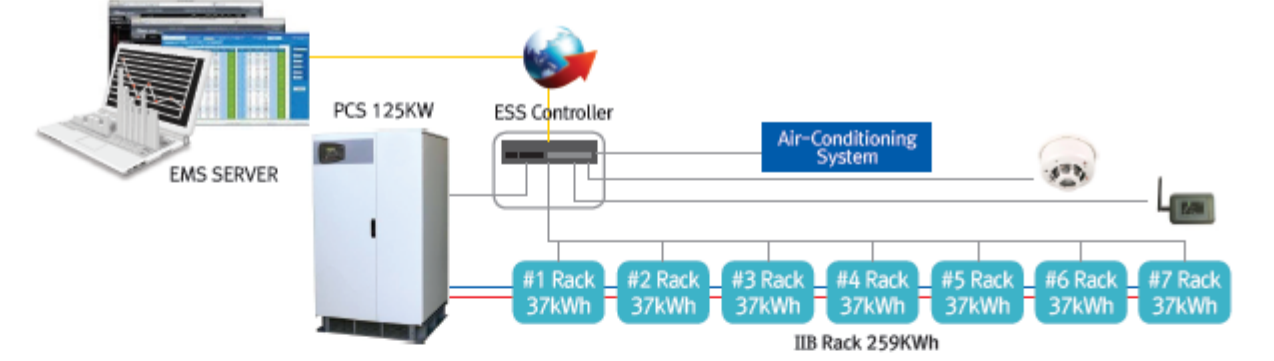

Each receptacle cell connected to commercial power lines can be partially charged directly from them and, if necessary, uses electrical power charged in the ESS. During the time of light power-load, Cells are to be charged. But, in the peak time of power load, as the energy saved in the ESS can be consumed, the high rate of cost possibly from the TOU rate system can be reduced.

Qualification & Honor (Patent , Certification & Award)





Application Applications of IIB products (ESS)

Application Applications of IIB products (ESS)

Apply power system ESS

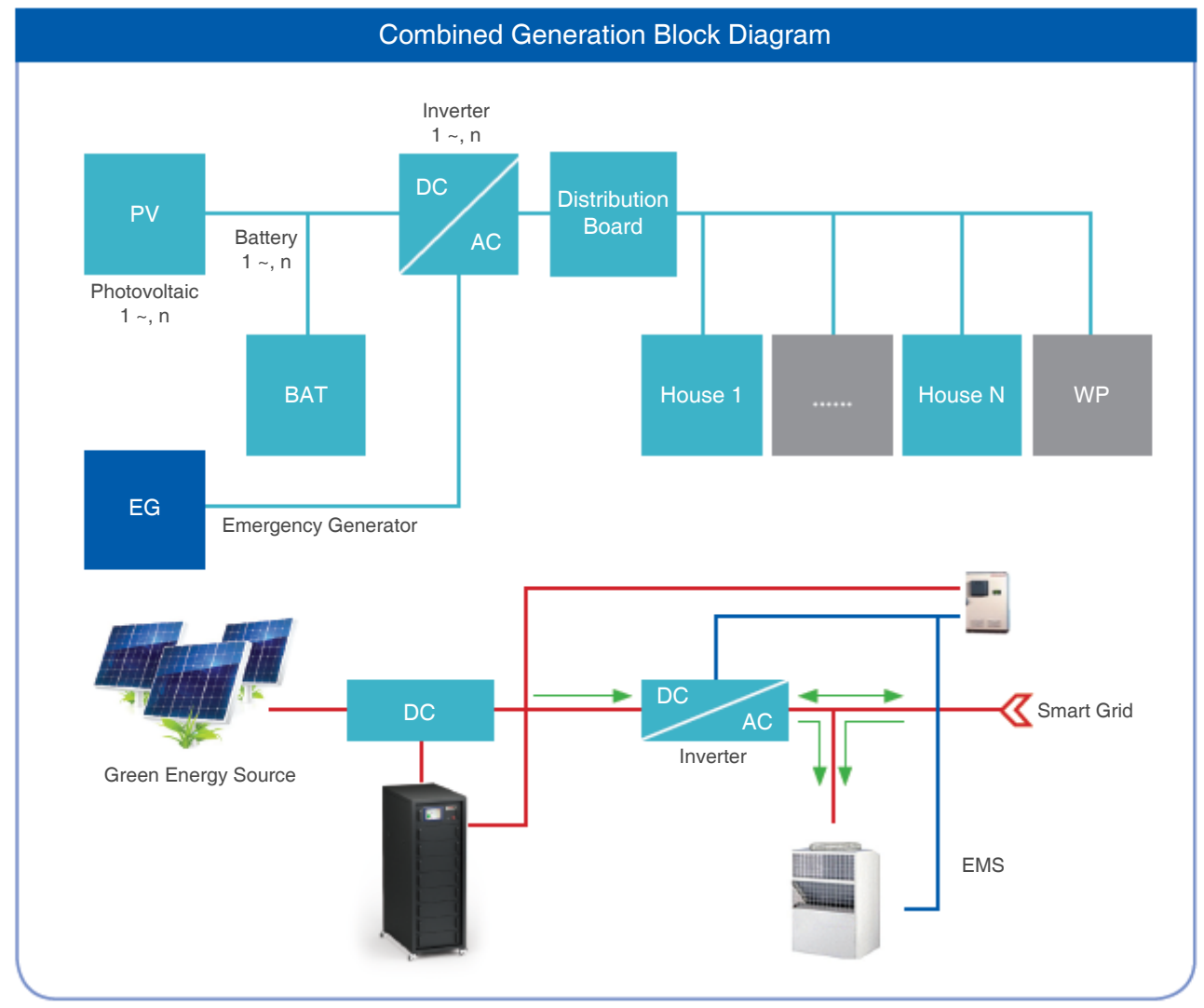

Sectors	Detail Sectors
Data Centers	Internet Computing Center, Financial Data Center, Corporate Data Center, Remote Backup Facilities
Communication	Telephone Office, Base Station, Computer Room, Server Room, Backup Center
Finance	Computer Room, Server Room, Backup Center
Government / Public Institution	Core Facility in Public Institution, Computer Room, Server Room, Backup Center
Military	Submarine for 209, 212, 214Grade
Core Facility	Computer Room, Backup Center in Airport, Hospital, Broadcasting Station, Military, etc

Green Energy & Power Plant		
Steel Mill, Oil-Refining Facility, Chemical Plant, etc		
National Assembly, City Hall, Government Branch		
Battleship, Submarine, Tank, Control Tower, Weapon System, Aviation Control		
Stock, Bank, School Computer Room		
Airport, Harbor, Railroad, Subway		